

Lubricate all seals with clean hydraulic fluid, prior to assembly. Do not use silicone type lubricants.

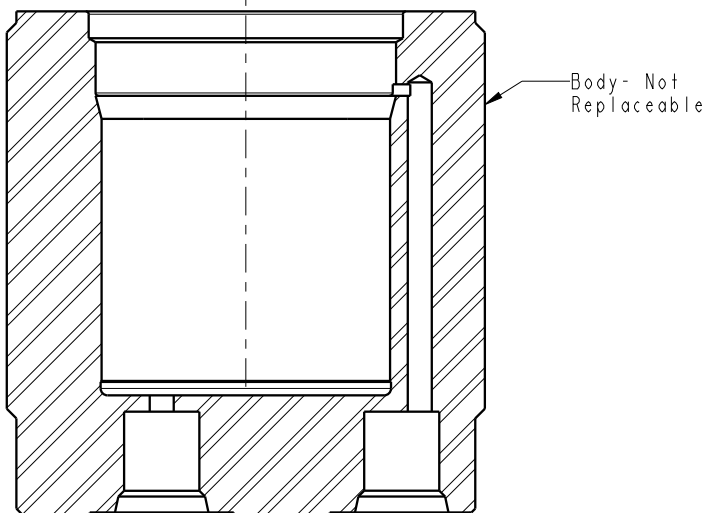
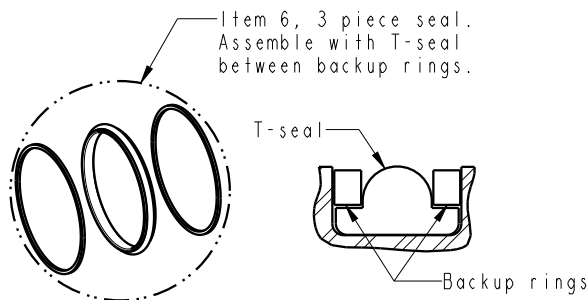
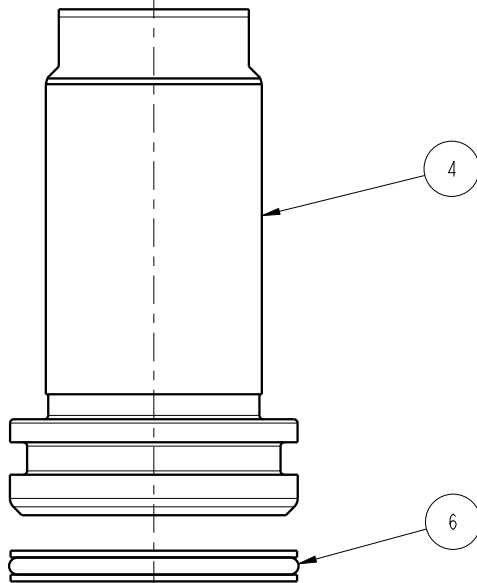
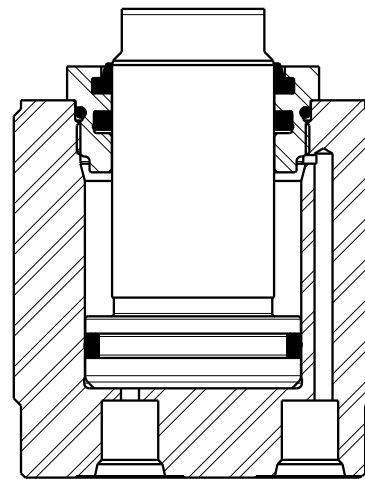
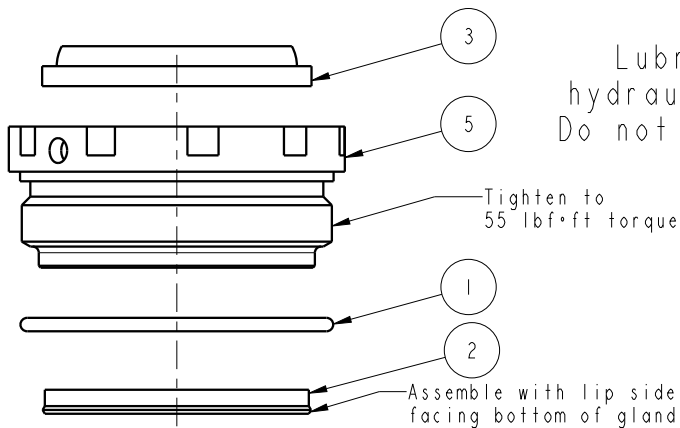

Standard Seal Kit	Fluorocarbon Seal Kit
60-2002-15	6V-2002-14
39-H110-31	39-H110-31
39-0110-48	39-0120-07
39-0010-13	39-0120-14
39-0500-20	39-0500-20

No.	QTY	PART No.	DESCRIPTION
6	1	39H11031	SEAL, T, (1 5/16X5/32X1 1/2)
5	1	82031501	GLAND, CYL, 8800 & 39.9 KN
4	1	82011505	PISTON, CYL, 8800, 1 STRK
3	1	39050020	WIPER, SNAP-IN, (1-1/8)
2	1	39011048	SEAL, LL, (1-1/8 X 1/8 X 1/8 X 1-3/8)
1	1	39001013	O-RING, (-029)

PARTS LIST	
	VEKTEK, INC. 1334 E. SIXTH AVE. P.O. BOX 625 EMPORIA, KS. 66801 U.S.A.
Model Number 20-0215-01 20-0215-01F	ASSY, CYL, TB, 8800, 1 STRK, DA
SIZE A	PL-2059
	REV G

G	5499	RELEASE	NPETERS	10/2/24
REV	IN ACCORDANCE WITH ECN	EFFECTIVE DATE	REVISED BY	DATE
DRW BY:	JACOB	DRAWING STATUS: Released PRODUCTION APPROVED FOR RELEASED STATUS ONLY		
DATE:	8/1/90			